



# CUTLERY DRYER SAS-5001 120/60/1

Floorstanding flatware polishing machine.



P/N 1370041

WARE WASHING  
CUTLERY DRYERS



## SALES DESCRIPTION

Output: up to 8000 pieces per hour

- ✓ Dries, polishes and removes lime scale stains from cutlery after washing.
- ✓ Fully automatic.
- ✓ Stainless steel body and polishing tank.
- ✓ Rounded cutlery carousel, avoiding cutlery jams.
- ✓ Economy: saves on personnel costs and quick return of investment.
- ✓ Speed: hourly output of up to 8,000 pieces.
- ✓ Hygiene: the germicidal UVC-ray lamp sterilises both the cutlery and the polishing product.

## INCLUDES

- ✓ Germicidal UVC-ray lamp.
- ✓ Drying-polishing product 5kg.

## ACCESSORIES

- Polishing product
- Front Wheel Kit



SAMMIC, S.L.  
Basarte, 1 - 20720 AZKOITIA  
www.sammic.com

**sammic** | [www.sammic.com](http://www.sammic.com)  
Food Service Equipment Manufacturer

Polígono Basarte, 1. phone +34 943 15 72 36  
20720 Azkoitia, Spain [sales@sammic.com](mailto:sales@sammic.com)



Project	Date
Item	Qty
Approved	

product sheet  
updated 11/01/2021



# CUTLERY DRYER SAS-5001 120/60/1

Floorstanding flatware polishing machine.



P/N 1370041

## SPECIFICATIONS

Hourly production (pieces): 5000 - 8000  
 Electrical supply: 120 V / 60 Hz / 1 ~ (10 A)  
 Plug: USA

### Loading

- ✓ Motor power: 300 W
- ✓ Element power: 900 W
- ✓ Uvc lamp power: 8 W

### External dimensions (WxDxH)

- ✓ Width: 630 mm
- ✓ Depth: 693 (800) mm
- ✓ Height: 783 mm

Net weight: 130 Kg

### Crated dimensions

923 x 760 x 850 mm  
 Gross weight: 140 Kg.

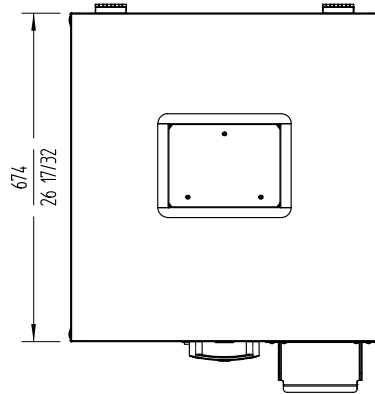
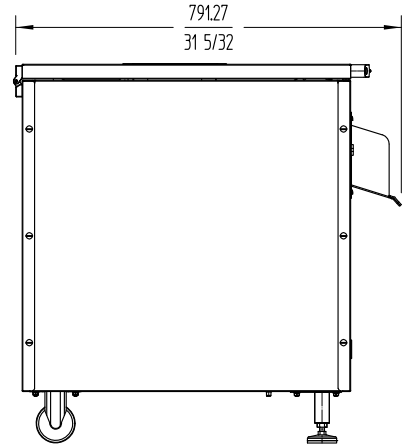
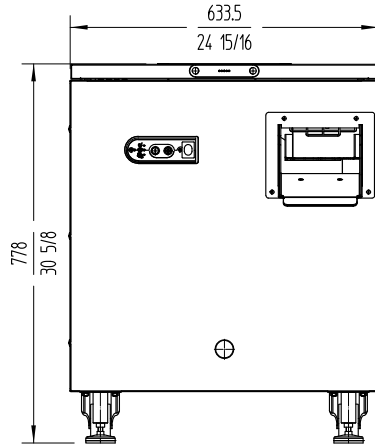

WARE WASHING  
CUTLERY DRYERS

 <b>sammic</b>   <a href="http://www.sammic.com">www.sammic.com</a> <b>Food Service Equipment Manufacturer</b> Polígono Basarte, 1. phone +34 943 15 72 36 20720 Azkoitia, Spain <a href="mailto:sales@sammic.com">sales@sammic.com</a>		Project	Date
		Item	Qty
		Approved	

product sheet  
updated 11/01/2021